

VS Series™

Variable Speed
Rotary Screw Compressors



Experience Proven Results™

Smarter Solutions

YOUR BUSINESS IS UNIQUE, SO IS YOUR COMPRESSED AIR SYSTEM

Typically, air demand in a plant varies widely throughout the day. In addition, fluctuations can occur from shift-to-shift, weekday-to-weekend, and season-to-season. Pressure requirements can also change from machine-to-machine or from one application to another. You need someone to evaluate your unique, often complex requirements and recommend a tailored solution.

THE WRONG SOLUTION IS EXPENSIVE

Compressed air is not free and has a big impact on plant productivity. The wrong air system is costly—in the form of excessive energy, repair and maintenance costs, downtime, poor compressed air quality, unacceptable noise levels, and more. System design and compressor choice are important decisions with long lasting implications.

THE VARIABLE SPEED COMPRESSOR—ONE SMART SOLUTION

Variable speed compressors can efficiently and reliably handle the varying air demand found in most plant air systems. These compressors speed up and slow down to match air supply to air demand as it fluctuates. The right variable speed compressor in the right application delivers significant energy savings and a stable, consistent air supply.

Poor system design can increase energy cost up to 5 times.

THE COMPLEX NEED— EVERY AIR SYSTEM IS DIFFERENT

PLANT AIR DEMAND OFTEN VARIES WIDELY OVER TIME

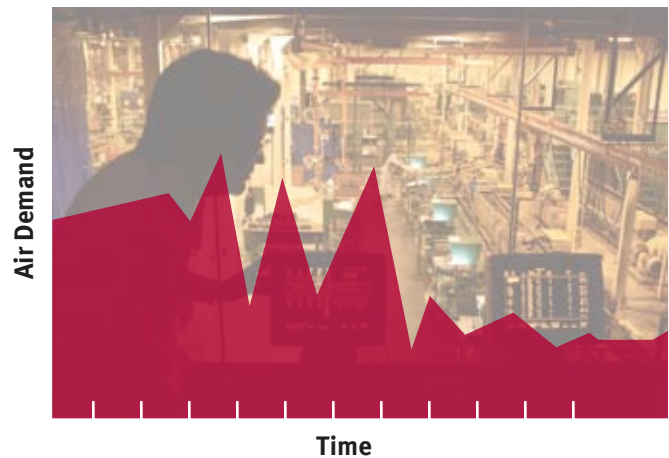

COST OF COMPRESSED AIR OVER 5 YEARS

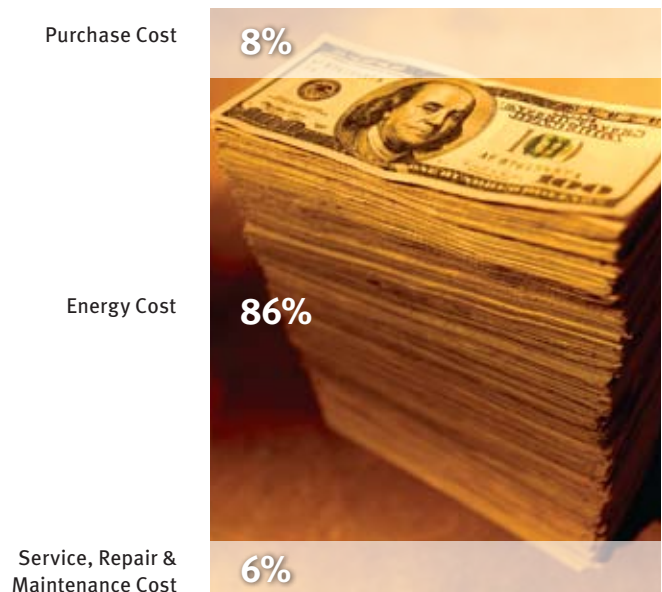

THE SMARTER SOLUTION— VS SERIES VARIABLE SPEED COMPRESSORS

THE VS SERIES—RETHINKING EVERYTHING

The VS Series design started from a “clean sheet of paper.” This approach is critical to making a variable speed compressor that delivers optimal performance over a wide operating range. For maximum reliability, key features must be part of the design foundation. With the VS Series, an international team of world-class engineers delivers a truly purpose-built compressor product line.

TECHNOLOGY PAVES THE WAY

Our engineering team utilized the latest technologies in developing the VS Series so that it is loaded with the critical product benefits you want. Important technologies used include:

- **Computational Fluid Dynamics (CFD)** to minimize pressure drop from the air inlet all the way to the air discharge of the compressor. This maximizes efficiency and minimizes your electrical cost of operation.
- **Finite Element Analysis (FEA)** to allow the strength and rigidity of a component to be completely understood. If a weak area is identified, design changes are made before the product is produced.
- **Solid Modeling** in the design phase allows these technologies to be applied successfully. In addition, product quality and serviceability are greatly enhanced when viewed and analyzed from a solid model.
- **Thermography** was utilized to maximize heat transfer and ensure that cool, clean compressed air is delivered to the plant.

All of these technologies are combined with a proprietary rotor profile design that optimizes efficiency across a broad operating range. **Smart!**



THE BENEFIT: EFFICIENT, RELIABLE, FLEXIBLE... UNMISTAKABLE

The VS Series is a complete, revolutionary compressor line that is a Smarter Solution to your Complex Needs. The efficiency limitations of competitive variable speed drive compressors have been eliminated to establish a new standard in this area. The flexibility of this line exceeds that of any other compressor. This means stable pressure in the plant and maximum productivity. Finally, the VS Series is so reliable it is backed by the best warranty in the business.



Efficiency

Delivering the Lowest Possible Electrical Cost

THE TYPICAL EFFICIENCIES OF THREE COMPRESSOR TYPES

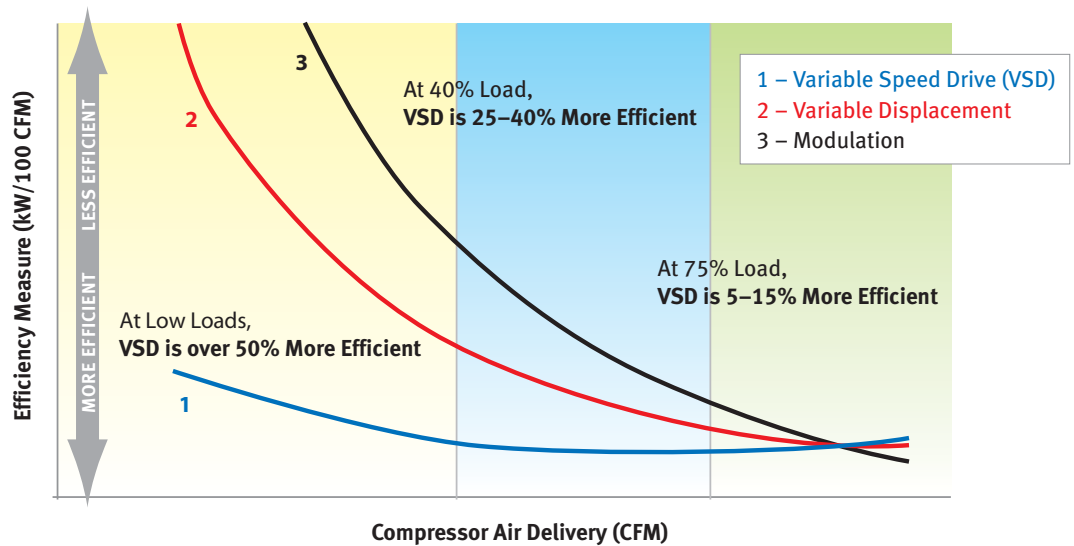

EVALUATE EFFICIENCY EVERYWHERE— FULL LOAD, PART LOAD, NO LOAD

Upper Range – Part Load Efficiency Gains Importance

At full load in the upper flow range (green area in graph at right), top performing base load-modulating compressors are typically better performers (curve 3). As air-flow decreases, the other compressor types become more energy efficient (curves 1 and 2).

Middle Range – VSD Takes Charge

In the middle range (blue area), the VSD compressor shows significant energy

savings compared to the other compressor types. At about 75% of a compressor’s full load flow, the VSD compressor is 5-15% more efficient, and the advantage increases as flow decreases.

Lower Range – VSD is Far Superior

In the lower range (yellow area), the VSD compressor savings become even greater. A variable speed compressor handling a second shift that uses only 40% of the air

requirements of the first shift is just one of many ideal applications for a VSD compressor.

ALL VSD COMPRESSOR EFFICIENCIES ARE NOT CREATED EQUALLY

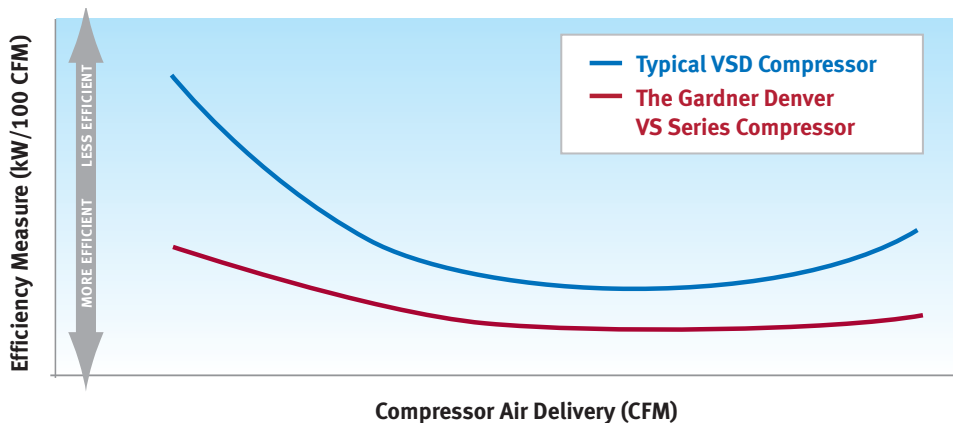

THE VS SERIES PROVIDES EFFICIENCY EVERYWHERE – FULL LOAD, PART LOAD, NO LOAD

Typical VSD compressors are not designed to maximize performance. Most manufacturers simply adapt their current products to a variable speed drive and motor. The VS Series products are specifically designed to obtain the greatest efficiency across the entire operating range.

TO MAXIMIZE EFFICIENCY, THE VS SERIES ELIMINATES EVERY POSSIBLE kW

Unlimited Start/Stop Operation – When air is not needed VS Series compressors stop running WITHOUT venting air you’ve already paid to compress. Thus, no power is used when no air is needed. When air demand returns, these compressors “soft” start against a pressure load. The result—energy consumption is kept to an absolute minimum.

Air ends Optimized for Variable Speed Operation – Gardner Denver invested millions of dollars to develop new air ends and new rotor profiles for the specific purpose of maximizing efficiency in variable speed compressors.

Enduro[®]+ air ends perform efficiently at all speeds



More Models to Choose From – Every platform of the VS Series has several models from which to choose. This means you can better match your needs to a specific compressor and get the best value for your application.

Designed for Minimum Pressure Drop – For every 2 PSIG of pressure drop through a compressor package an additional 1% of power is consumed. That’s why every area on these compressors was designed so that air flows with the least possible restriction.

The Efficiency Foundation— A Matched Motor, Drive and Air End

We started with an air end and rotor profile design that offers industry leading turndown and performance. We partnered with an industry leader to develop a perfectly matched motor and variable speed drive to work with our air end for optimum efficiency and turndown capability. VS 15–170 kW (20–228 HP) models are direct drive, so there are no efficiency losses from belts.

Flexibility to Surpass Your Goals

CAPABILITY TO MEET VARYING COMPRESSED AIR DEMANDS

- Shift-to-shift, weekday-to-weekend, or season-to-season... we offer the widest turndown range in the industry. In other words, we have a greater capability to handle variable air demand requirements.
- Selectable pressure from 70–175 PSIG at the touch of a button—no need for a new compressor when your pressure requirements change.
- Quick response to pressure changes that maintains target pressure within ± 1 PSI. This provides stable plant pressure resulting in higher productivity.
- Full line of compressors to match your compressed air requirements from 11–170 kW. With more models we can perfectly match your needs.
- Optional integrated dryer through the 70 kW model allows compact, space-saving installation.

The VS Series saves time, saves money, maximizes plant productivity—It's like having several efficient compressors in one. Smart!



Reliability

To Maximize Uptime

DESIGNED FOR RELIABILITY

We used a “clean sheet of paper” design approach, with all components carefully selected and tested for their specific performance and purpose.

The VS Series design incorporates *smart injection technology* which communicates with the AirSmart™ controller to maintain the discharge temperature of the compressor above the dew point (based on the ambient temperature of the operating environment) to prevent condensate from forming in the lubricant. **Smart!**

Gardner Denver’s integrated Tempest design through the 70 kW model eliminates leak points through smart, efficient, latest technology construction. Our new Enduro+ air ends for the 80 kW and larger models were developed to be more efficient and reliable than ever.

A Warranty Like No Other

In simple terms, VS Series compressors have a best in class warranty. The five-year warranty covering the drive motor, air end, variable frequency drive, controller, and more is unparalleled. With regular lubricant, sampling, and use of OEM parts and lubricant, you are guaranteed to have a compressor that exceeds your reliability expectations.



Gardner Denver’s Integrated Tempest® Unit

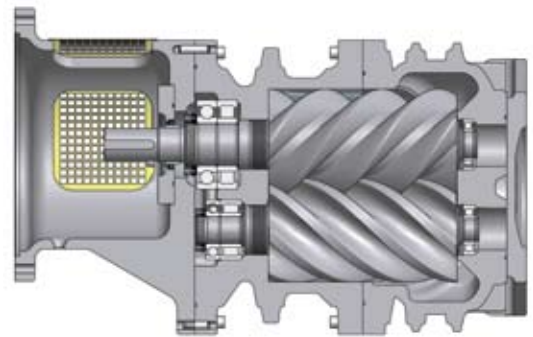

Cutaway of Gardner Denver Enduro®+ Air End

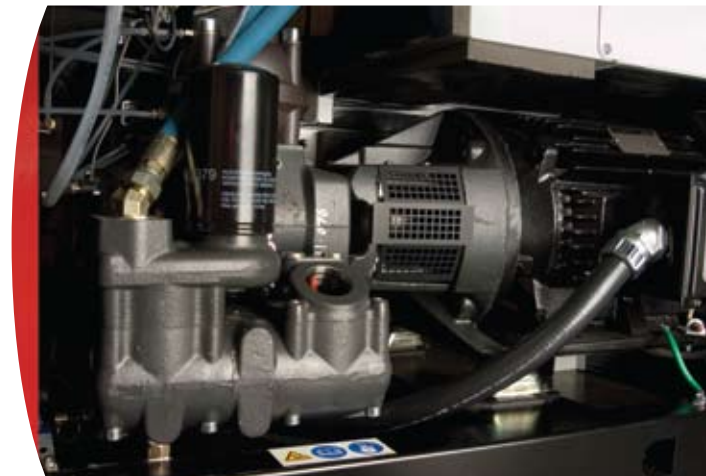

The AirSmart™ Controller

Orchestrating Your Compressed Air System

Simplicity

The AirSmart Controller was designed to make the operator interface with the variable speed drive transparent. You don't need to be an expert on variable speed drives to operate our compressor. The controller takes care of the details.

The controller automatically adjusts the compressor performance to meet your changing air system demands—saving you energy dollars.

Changing the discharge pressure is as easy as pressing a button. No longer is there a need for a new machine when your pressure demands change.

Communication & Sequencing

The optional communication module allows the VS Series units to talk to each other and other Gardner Denver compressors to optimize system efficiency. This isn't just an hour-balancing, on/off sequencing scheme. Our controller allows the system to truly optimize efficiency because it knows the capabilities of other machines and orchestrates their operation.

The communication module also allows remote monitoring of the VS units.

Expansion Capabilities

Also available is an optional expansion module that allows additional I/O capabilities for additional monitoring equipment, such as a pressure transducer. The expansion I/Os are standard on VS 80–VS 260.

Advanced Display

The controller has a four line display with menus and tactile buttons for easy navigation. Two lines display operating information such as pressure, temperature, operating hours, etc., while the other two lines display advisory messages, shutdown messages, recommended part numbers, and service contact information.



100 PSI
326 HRS
ENERGY COST 3.78 \$/KWH

88°F
AUTOMATIC
LOADED 75%

SHUTDOWN
SERVICE
AUTOMATIC
POWER

ENTER

STOP/RESET

RUN

Energy Efficient at All Load Levels

COMPRESSOR ENERGY COST ESTIMATOR

Nominal kW	Operating Cost per Year (5000 hours) at Cost per kWh (\$)				
	\$.04	\$.06	\$.08	\$.10	\$.12
55	11,000	16,500	22,000	27,500	33,000
75	15,000	22,500	30,000	37,500	45,000
90	18,000	27,000	36,000	45,000	54,000
110	22,000	33,000	44,000	55,000	66,000
150	30,000	45,000	60,000	75,000	90,000
180	36,000	54,000	72,000	90,000	108,000
220	43,600	65,400	87,200	109,000	130,800
260	52,000	78,000	104,000	130,000	156,000

Note: Hours of operation based on two 8-hour shifts, 6 days per week.
Calculations based on nominal kW.



The single largest “cost” item, during the life of a compressor is the cost of the electricity required to run the compressor. With *esaver*, the Gardner Denver Rotary Screw Energy Cost Calculator, no matter what load demand, the cost of the electricity used by a compressor can be calculated. Ask your local Gardner Denver Authorized Distributor to demonstrate this unique cost-saving tool.



Making Your Job Easier

ENVIRONMENT

Serviceable Yet Compact Footprint

Our entire VS line was designed with a compact footprint for space-saving, money-saving installation.

Super Low Sound

All VS models are enclosed for quiet, environmentally-friendly and employee-friendly operation.

Low Oil Carry-Over

The VS Series performs with only 2-3 ppm of oil carry-over, measured *before* the aftercooler, across the *entire* operating range. This responsible approach minimizes disposal cost, lubricant expense and assures air quality.



Gardner Denver, an **ENERGY STAR PARTNER**, is committed to developing products and introducing technologies that help conserve energy and protect the environment.

SERVICEABILITY & PRODUCT SUPPORT

Serviceability

Great attention was given during the design of the VS line to ensure that our compressors are easy to service and maintain.

Support Network

Gardner Denver has a network of trained service providers available whenever needed to keep your compressors in top form. We are committed to stocking components to support your compressed air system needs.

Aftermarket Products

Gardner Denver carries a full line of aftermarket products to meet your full system needs.

We thought of
everything—
a **SMARTER SOLUTION**
all the way around!



<http://www.esp2020.com>

ESP 20/20

Single Compressor Remote Monitoring

ESP 20/20 is a wireless remote monitoring solution that upgrades the air compressor to an intelligent asset providing system performance and advisory notification. Interfacing directly to Gardner Denver or third party compressors via discrete inputs and outputs, any compressor asset can be transformed to provide critical operational information through a single web-based application.

WIRELESS:

Installation Has Never Been Easier

One of the unique features of ESP 20/20 remote monitoring is wireless access to the compressor. This feature is only offered by Gardner Denver's ESP 20/20 and provides significant advantages over IP/Network or RS232/Serial based systems.

- Eliminates time and expense of running CAT5 or other types of cabling to the compressor.
- Eliminates IP configuration and Network setup.
- No need to access IT experts for installation.
- Remote monitoring channel is isolated from your IP network for excellent security.
- Flexibility in where a compressor can be located.
- Ease of relocating a compressor, if needed, without having to re-route wires.



Avoid IT wiring headaches with a wireless solution

ENTERPRISE/WEB BASED SOLUTION:

Anytime, Anywhere Access

ESP 20/20 is an enterprise web-based solution, a Gardner Denver exclusive feature, which provides substantial advantages over peer to peer solutions offered in most competitive products.

- Allows multiple compressor assets, at single or multiple locations, to be viewed from single web-based interface.
- No application software needed to view and monitor compressor assets.
- Easy access from any computer anywhere with access to the internet.
- Enterprise password protection allows passwords to be assigned to specific personnel at appropriate levels.
- Alert preferences for personnel are assignable to meet individual needs.
- Automatic notifications of advisories, alarms, or scheduled maintenance via email, text, page, or voice to match today's mobile technology and work environment.

GD XTRA
10 Year Protection

ESP 20/20 qualifies the compressor for **GD XTRA**, Gardner Denver's extended warranty program on airends, delivering the tools to ensure the compressor is operating at peak performance with the peace of mind that the compressor is protected.

Let Gardner Denver Take Control of Your System

To ensure total system reliability, Gardner Denver provides a broad range of dryers, filters, oil/water separators, drains, cleaning fluids, and aftercoolers. ONE-STOP shopping from Gardner Denver assures that all components of the system are designed to work together and are backed by customer support today and for years to come.



FIL Series High Efficiency Filters

A full range of filters 20–21,250 cfm; coalescing, particulate, and activated carbon for the removal of water, oil, and particulates from compressed air.



DS2 Series Evacuator Drain Valves

A full family of zero air loss, energy efficient demand drains. Ruggedly designed to effectively and reliably prevent moisture damage to dryers, air tools, gauges, and other critical components.



RNC Series Refrigerated Dryers

A full line of high quality refrigerated dryers with features and benefits unmatched by the competition. Designed to produce dew points as low as 38°F in compressed air.



DGH Series Desiccant Dryers

A complete line of desiccant dryers for the removal of water vapor in compressed air to dew points as low as -100°F.

Gardner Denver®

www.GardnerDenverProducts.com maggie@gardnerdenver.com

Gardner Denver, Inc. 1800 Gardner Expressway, Quincy, IL 62305
Telephone: (800) 682-9868 FAX: (217) 224-7814

©2010 Gardner Denver, Inc. Printed in U.S.A. GS-VS-FAM 2nd Ed. 1/10



Member



Please recycle after use.